

LIQUID CHOCOLATE/COMPOUND/SPREAD CREAM PRODUCTION

SOTU50 for liquid chocolate/compound and spread cream production up to 50KG/H

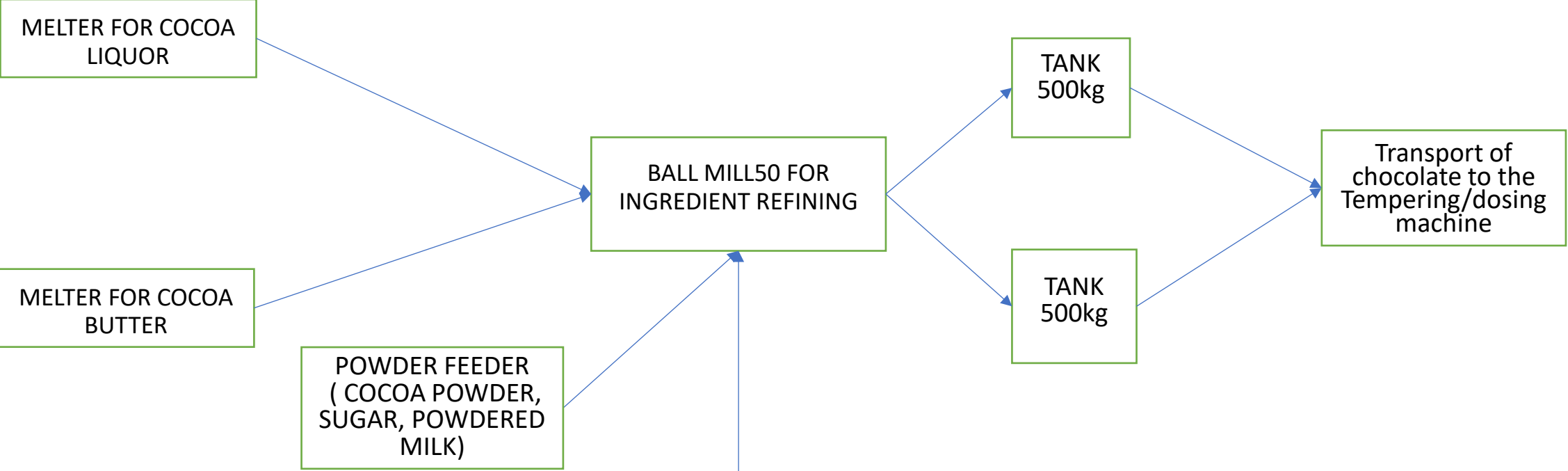

*NUT PASTE CAN BE BOUGHT OR SIMPLY PRODUCED WITH OUR BALLMILL. IT CAN BE PRODUCED IN PARALLEL WITH A 10KG/H BALL MILL OR WITH THE SAME 50KG/BALL MILL OF THE SOTU50 LINE

CHOCOLATE TABLETS PRODUCTION

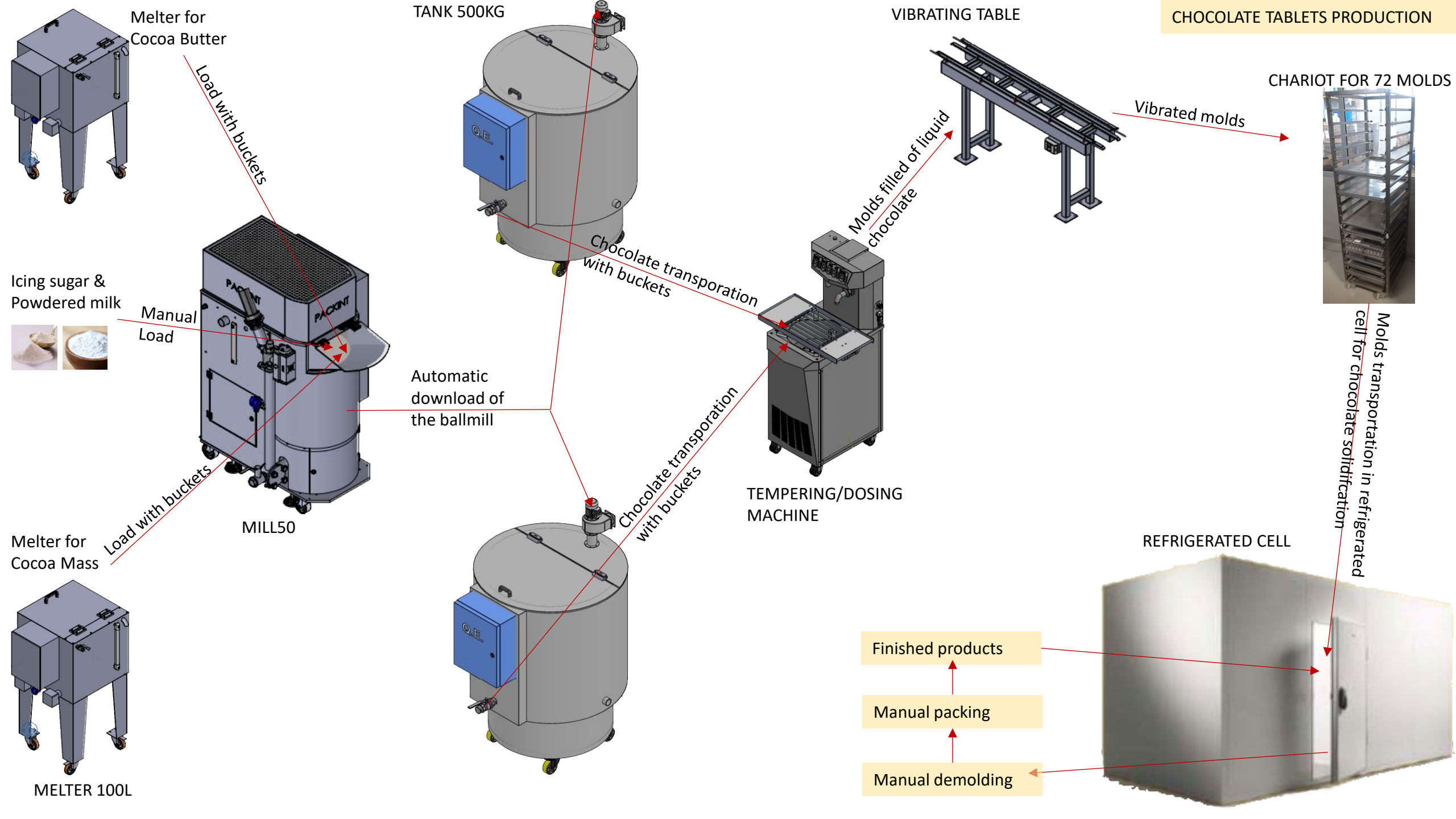

Melter for Cocoa Butter

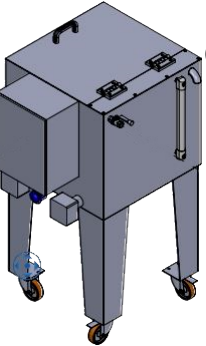

Load with buckets

TANK 500KG

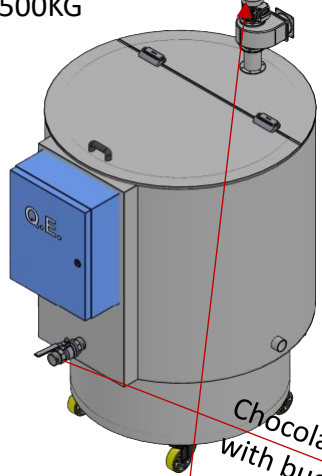

Chocolate transporation with buckets

Icing sugar & Powdered milk



Manual Load

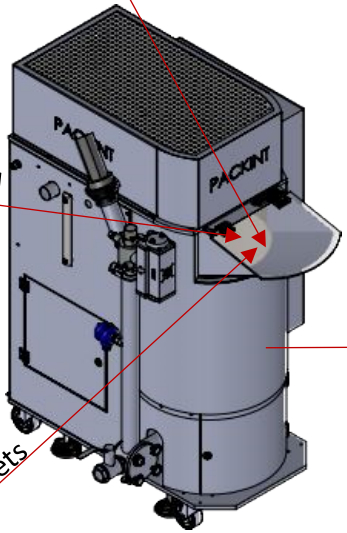

MILL50

Automatic download of the ballmill

Melter for Cocoa Mass

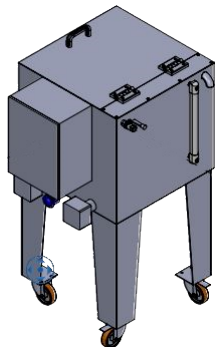

MELTER 100L

Load with buckets

Chocolate transporation with buckets

TEMPERING/DOSING MACHINE

Molds filled of liquid chocolate

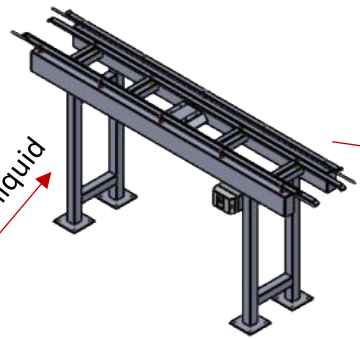

Vibrated molds

CHARIOT FOR 72 MOLDS



Molds transportation in refrigerated cell for chocolate solidification

REFRIGERATED CELL

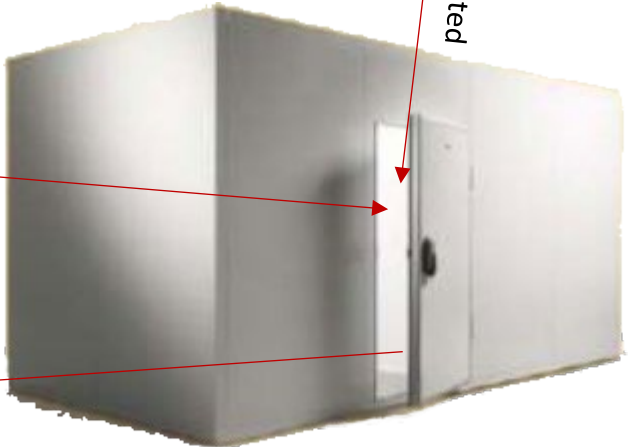

Finished products

Manual packing

Manual demolding

LAYOUT EXAMPLE OF SPREAD CREAM LINE

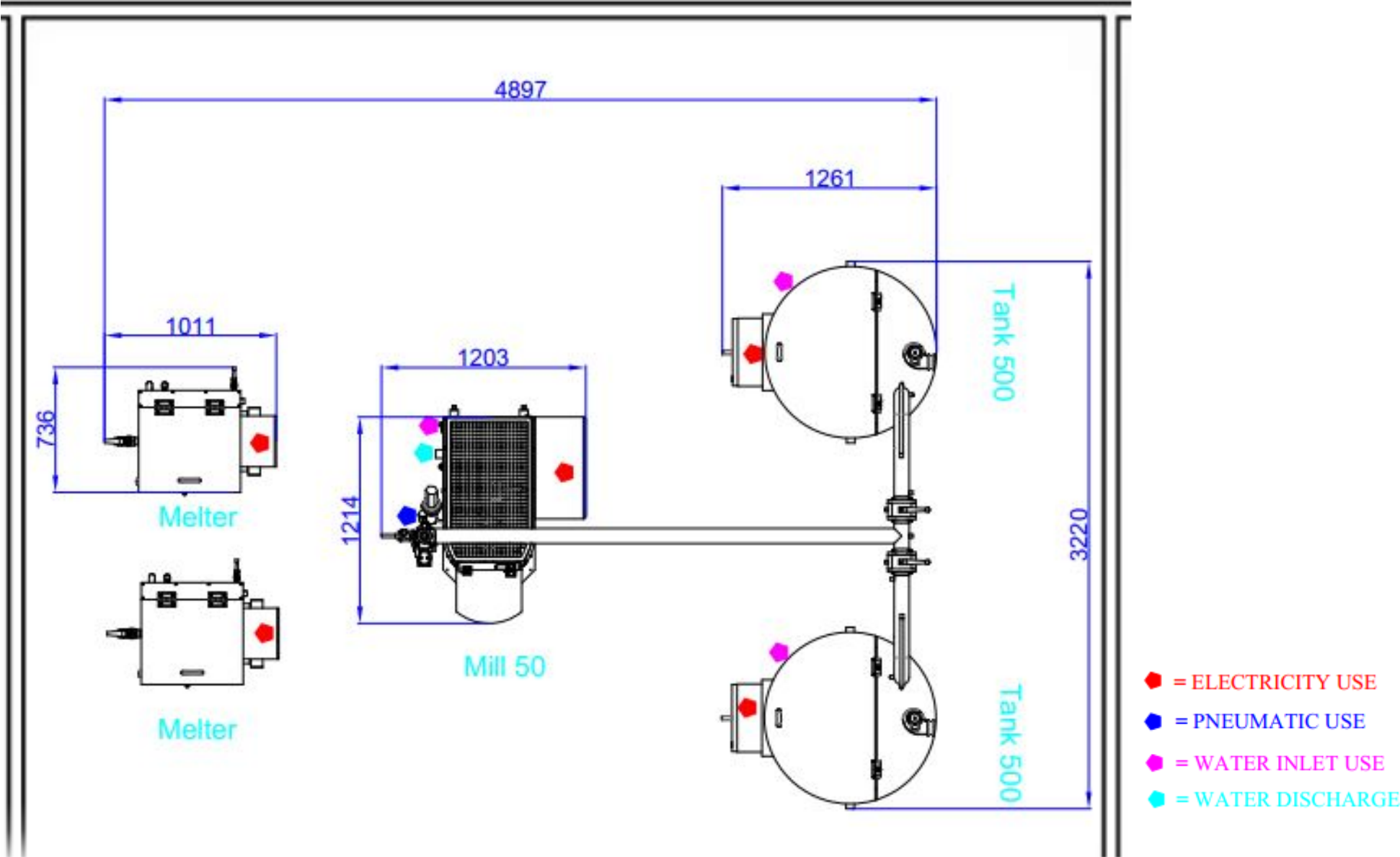



SOTU50



50Kg/h PROCESS LINE



